

	SERVICE INFORMATION	2-6
---	--------------------------------	------------

Subject: Clutch Sticking in the Engaged Position

Numerous warranty claims have been sent in with the condition found to be that the clutch was stuck in the engaged position. On most of these claims the clutch was replaced. After further inspection by BCS America, we found that the clutches were not defective, the cones inside just needed to be broken free. *In the future these claims will not be paid unless there has been an effort to repair the original clutch.* To repair a clutch that is stuck in the engaged position, follow these few steps:

- 1) Remove engine from transmission.
- 2) Loosen jam nut and set screw (Ref. #1) and remove clutch from engine.
- 3) Place the clutch in a vise (Ref.#2) in the position shown below.
- 4) Be sure to leave the cone pusher & bearing assembly (Ref.#3) on the clutch.
- 5) Tighten the vise until the cones separate from each other (you will hear and feel a slight pop when the cones break free.)
- 6) Spray a liberal amount of WD-40 or an equivalent lubricant into holes (Ref.#5).
- 7) Remove clutch from vise and install back on engine.
- 8) Install the engine onto the transmission making sure that the tab on the cone pusher (Ref.#4) is turned in the downward position and the clutch lever is resting on that tab.
- 9) Run the machine to make sure the clutch is engaging and disengaging properly. You may experience a brief bit of slipping and smoking while the clutch is burning off the lubricant and resurfacing the cones.
- 10) Instruct the customer that to prevent this from happening again, always lock the clutch lever (Ref.#6) in the upright, disengaged position, using locking tab (Ref.#7), when storing the unit.

Note: If this failure is experienced with an earlier style cone or disc clutch, you will be able to repair them by using the same basic procedure.

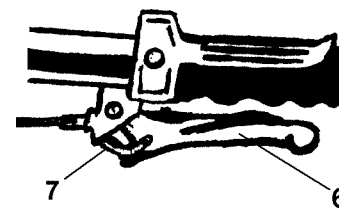
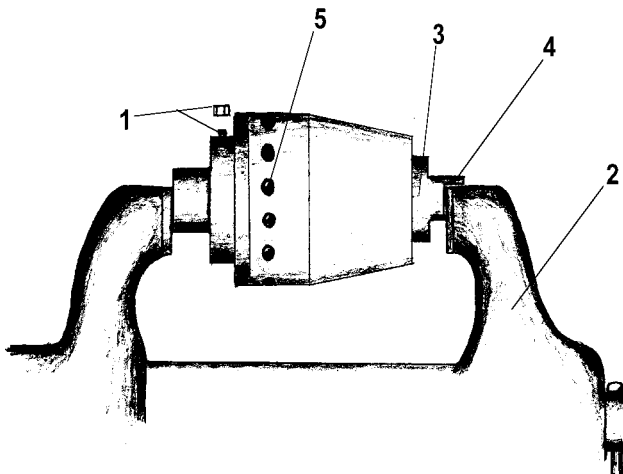

5498BD